



NOTE

All numerical values are in metric units [with U.S. customary units in brackets]. Dimensions are in millimeters. Unless otherwise specified, dimensions have a tolerance of ± 0.13 mm and angles have a tolerance of $\pm 2^\circ$. Figures and illustrations are for identification only and are not drawn to scale.

1. INTRODUCTION

This specification covers the requirements for application of ANSI C136.41 Dimming Receptacles with integrated gasket typically used for roadway and area lighting. All contacts are pre-installed into the receptacle housing and pre-crimped with 14 AWG stranded wire used on the three line voltage AC circuits and 18 AWG wire used on the four signal dimming control voltage DC circuits. Receptacle assemblies are available with both 105°C and 150°C rated wire. Receptacle assemblies are also available with either 2 or 4 dimming control pad-style contacts.

When corresponding with TE Connectivity (TE) Personnel, use the terminology provided in this specification to facilitate inquiries for information. Basic terms and features of this product are provided in Figure 1.

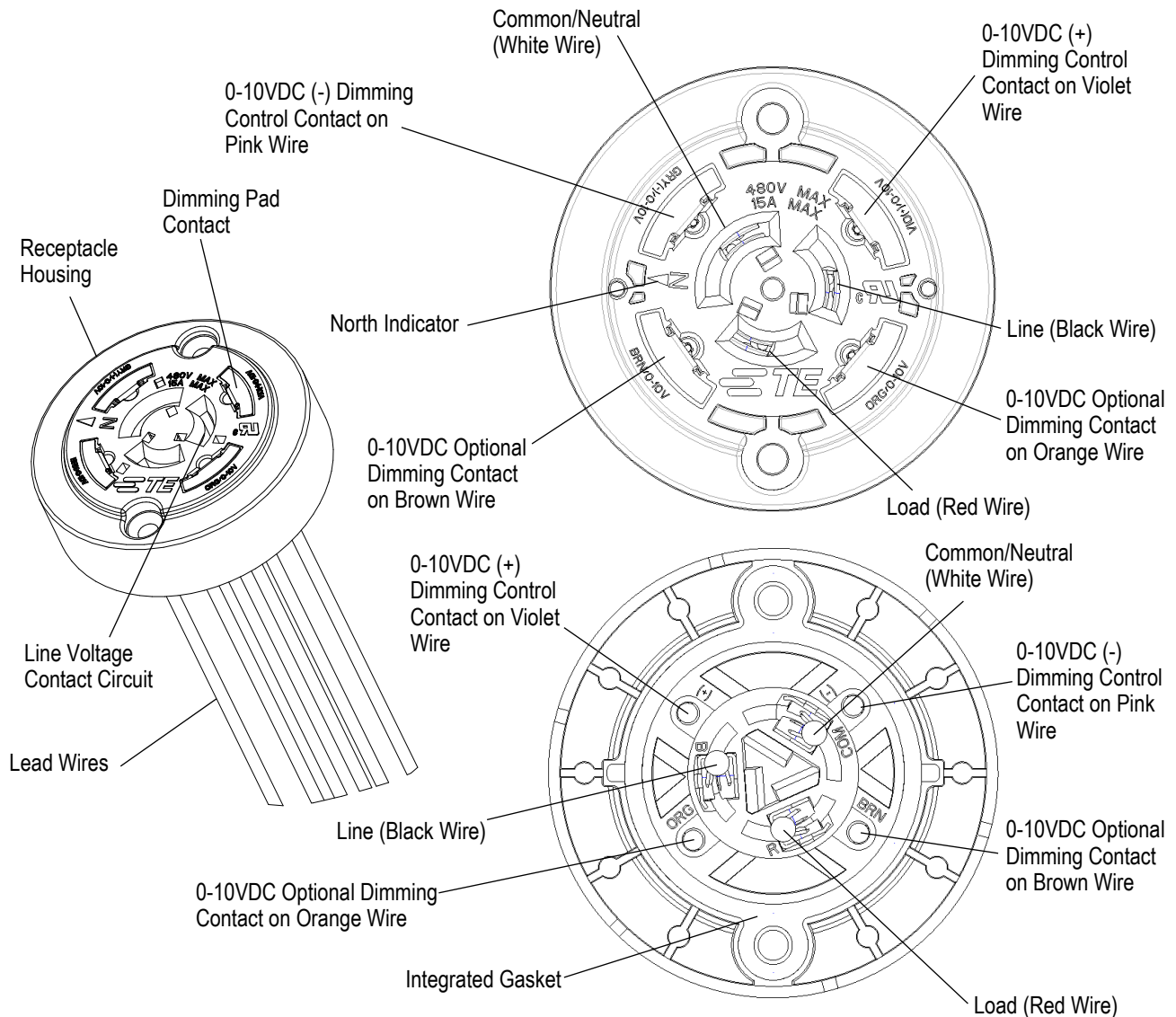

Figure 1

2. REFERENCE MATERIAL

2.1. Revision Summary

Release to Rev A

2.2. Customer Assistance

Reference Product Base Part Number 2376865-[] and Product Code K50 are representative of the ANSI C136.41 Dimming Receptacles. Use of these numbers will identify the product line and help you to obtain product and tooling information. Such information can be obtained through a local TE Representative, by visiting our website at www.te.com, or by calling PRODUCT INFORMATION or the TOOLING ASSISTANCE CENTER at the numbers at the bottom of page 1.

2.3. Drawings

Customer Drawings for product part numbers are available from the service network. If there is a conflict between the information contained in the Customer Drawings and this specification or with any other technical documentation supplied, the information contained in the Customer Drawings takes priority.

2.4. Specifications

Product Specification [108-160322](#) provides product performance and test information for the ANSI C136.41 Dimming Receptacle.

3. REQUIREMENTS

3.1. Safety

Perform all wiring of receptacle with power turned OFF.

3.2. Limitations

The connectors are designed to operate in a temperature range of -40° to 85°C [-40° to 185°F].

3.3. Material

The housing is made of UL 94V-0 rated thermoplastic. The line voltage contacts are made of copper alloy. Dimming pad contacts are made of copper alloy with gold plating in contact pad area, tin plated in wire crimp area with nickel under-plate on entire contact.

3.4. Storage

A. Shelf Life

The product should remain in the shipping containers until ready for use to prevent deformation to components. The product should be used on a first in, first out basis to avoid storage contamination that could adversely affect performance.

B. Chemical Exposure

Do not store product near any chemical listed below as they may cause stress corrosion cracking in the material.

Alkalies	Ammonia	Citrates	Phosphates	Citrates	Sulfur Compounds
Amines	Carbonates	Nitrites	Sulfur Nitrites		Tartrates

3.5. Handling

The receptacle assembly is supplied with integrated gasket and is ready to install upon receipt. It is recommended to avoid contact with dimming contact pads on the top of the receptacle as to not contaminate the electrical contact pad mating surface.

3.6. Receptacle Mounting

A. Mounting

A flat surface shall be provided on luminaire housing to mount receptacle assembly with integrated gasket. The mounting surface should have a flatness tolerance of 0.25mm or less. To provide water-tight mounting, it is recommended that the seal surfaces between receptacle assembly and luminaire housing are clean and free from any debris. The receptacle housing has two mounting holes which accept #8 or M4 size flat bottom screws. Screws of the appropriate length and type must be determined by the luminaire manufacturer. Since the receptacle has an integrated gasket, a screw torque of 1.0 to 2.0 N-m is recommended. Do NOT exceed 3.0 N-m. **Do Not mount the Receptacle with a screw that has a counter-sink style head.** See Figure 2.

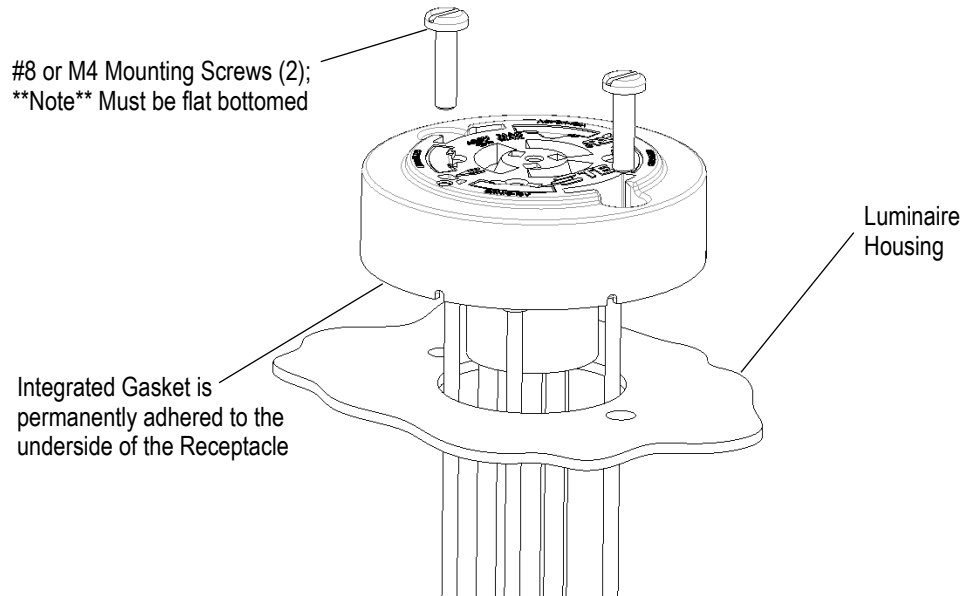

Figure 2

B. Mounting Hole Pattern

The recommended mounting hole pattern is shown in Figure 3.

Recommended
Mounting Layout

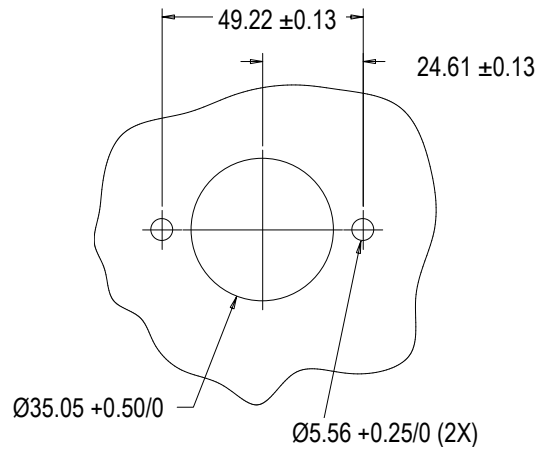

Figure 3

C. Mounting Location and Orientation

Locate the receptacle where artificial light cannot fall on the mating photocell causing it to turn off or cycle (on and off) at night. If possible, orient the receptacle so the North indicator points North.

D. Workmanship

The housing must not be damaged in any way. There shall be no nicked wire insulation.

3.7. Wire Connections and Diagram

A. Wire Connections

The receptacle wires must be appropriately spliced with the correct line voltage power or dimming signal source. When splicing lead wires with crimp-style splices, wire nuts, etc., ensure the proper size splicing connector per the manufacturer's recommendation is being used.



DANGER

Extreme caution must be taken to ensure that power is OFF prior to disconnecting or connecting any wires to prevent electrical shock.



NOTE

All wire connections must be electrically insulated.

B. Wiring Diagram

The receptacle wires must be appropriately spliced with the correct line voltage power or dimming signal source. Refer to the wiring diagram example shown in Figure 4. Wiring diagram shown is for general information only. Luminaire manufacturer must determine wiring diagram based upon their ballast/driver with dimming control components.

Wiring Diagram
(For General Information Only)

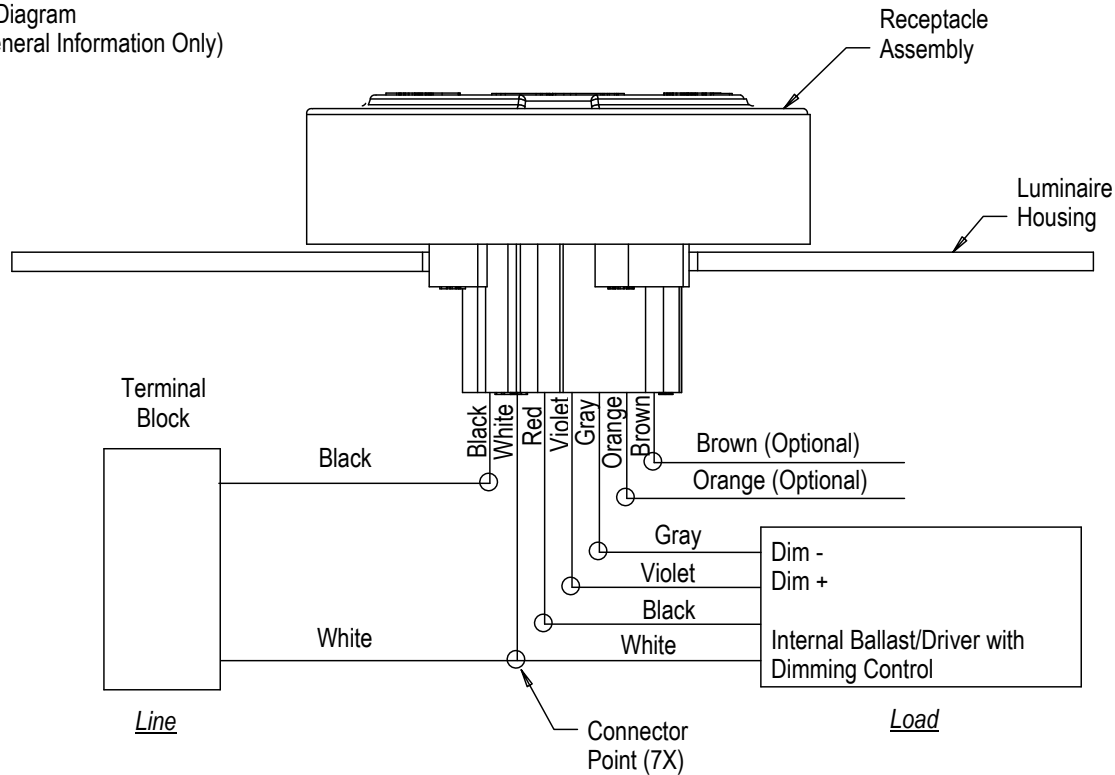

Figure 4

Luminaire is a trademark.

3.8. Strain Relief

It is recommended that a means be provided to support the wire bundle extending away from the receptacle assembly to prevent inadvertent application of high force to the wire bundle from transmitting into the wire/connector interface. The suggested strain relief method is to use a cable tie and anchor mounted inside the luminaire.

3.9. Mating and Un-mating Photocell to Receptacle

Align photocell blades with receptacle power contact circuits. Note that the neutral photocell blade is larger than the line and load blades, providing mating polarization. After properly aligning the blades to the receptacle power contact circuits, push downward until the photocell is bottomed on the receptacle's mating surface, slightly compressing gasket of the photocell. Then complete mating by twisting the photocell in a clockwise direction. The photocell will lock into position. To un-mate, reverse the aforementioned mating process. Reference Figure 5.

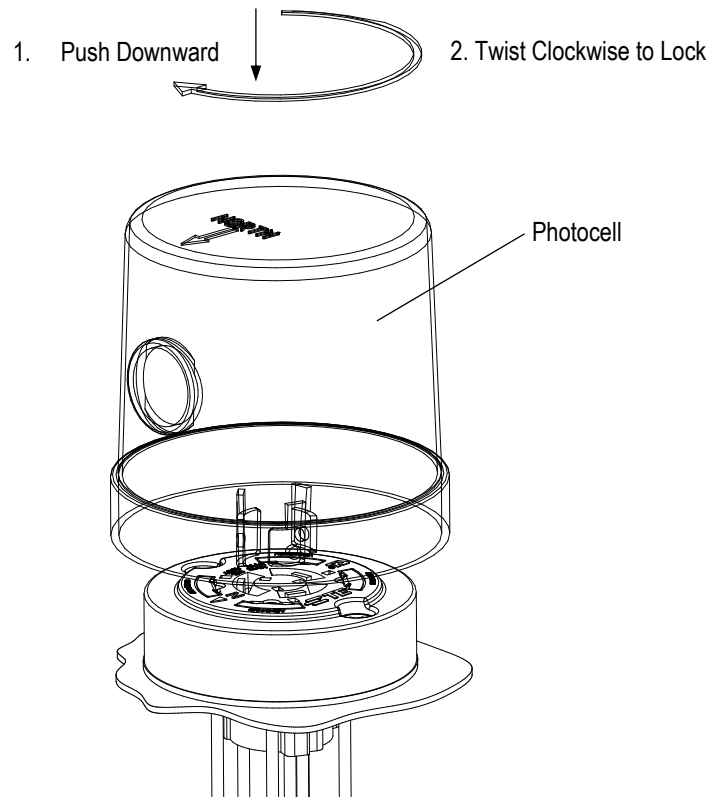

Figure 5

3.10. Replacement and Repair

The contacts and housings are not repairable. DO NOT use an assembly with damaged or defective contacts and/or housings. If damaged, replace the receptacle assembly with a new one.

4. QUALIFICATIONS

ANSI C136.41 Dimming Receptacles with integrated gaskets are Component Recognized by Underwriters Laboratories, Inc. in File E66375, Volume 5, and have been Investigated to CSA International by UL.

ANSI C136.41 Dimming Receptacles with integrated gaskets have been evaluated to IEC-61984 by Underwriters Laboratories, Inc. and is included in CB report certificate US-37285-UL.

5. TOOLING

No special tooling is required for the installation of this product line.

6. VISUAL AID

The illustration below shows a typical application of ANSI C136.41 Dimming Receptacles. This illustration should be used by production personnel to ensure a correctly applied product. Applications which DO NOT appear correct should be inspected using the information in the preceding pages of this specification and in the instructional material shipped with the product or tooling.

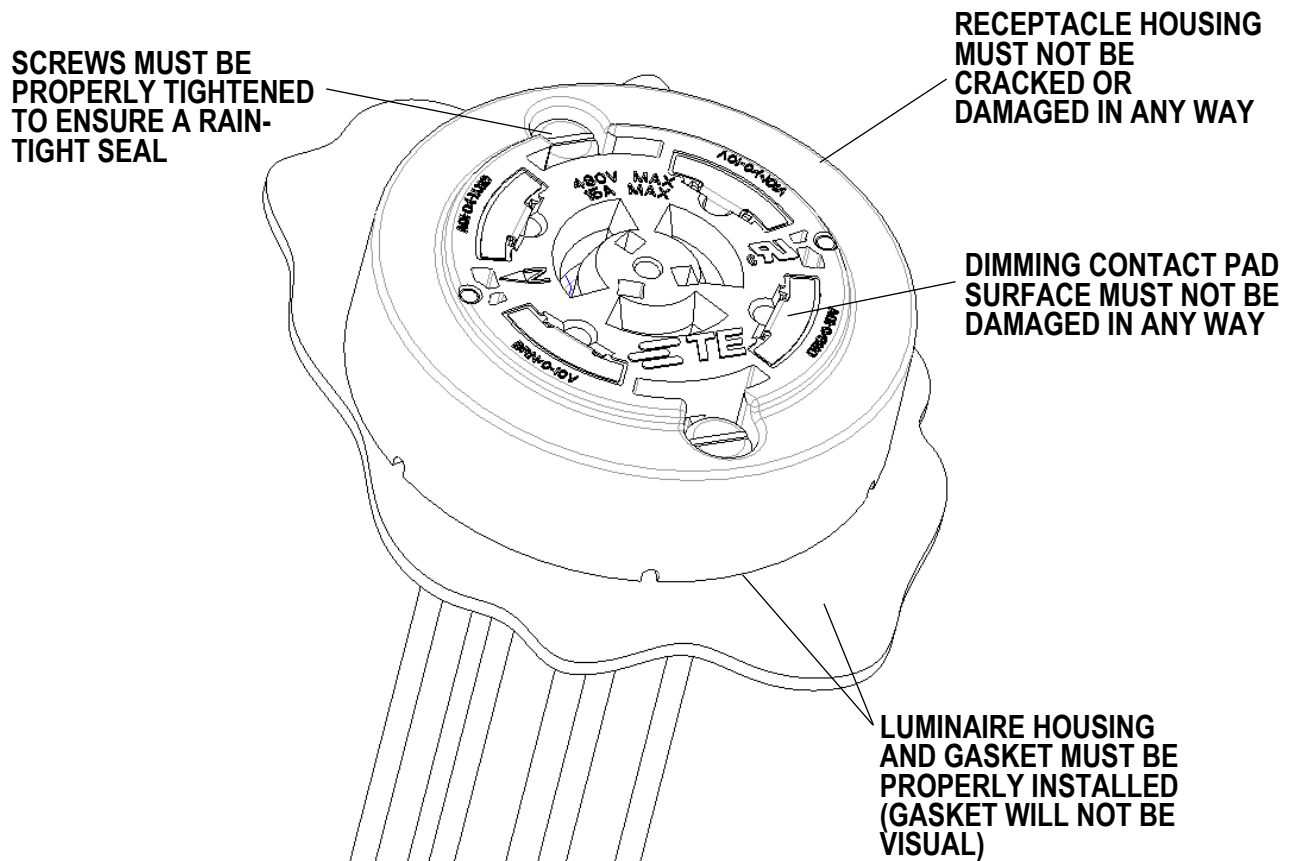

FIGURE 6. VISUAL AID