

PLT-SEC-T3-3S-230-FM - Type 3 surge protection device



2905230

<https://www.phoenixcontact.com/us/products/2905230>

Please be informed that the data shown in this PDF document is generated from our online catalog. Please find the complete data in the user documentation. Our general terms of use for downloads are valid.



Plug-in device protection, according to type 3/class III, for 3-phase power supply networks with separate N and PE (5-conductor system: L1, L2, L3, N, PE), with integrated surge-proof fuse and remote indication contact.

Your advantages

- Surge protection family for universal use with optimum energy coordination from the lightning current arrester to the device protection
- Easy to maintain due to consistently pluggable protection modules
- Excellent level of information provided by mechanical/visual status indicator and remote indication contact
- Optimal additional protection of the industrial power supply for a longer service life and increased availability of the system

Commercial data

Item number	2905230
Packing unit	1 pc
Minimum order quantity	1 pc
Sales key	CL19
Product key	CL14A1
Catalog page	Page 82 (C-4-2019)
GTIN	4046356939706
Weight per piece (including packing)	156.3 g
Weight per piece (excluding packing)	156.3 g
Customs tariff number	85363090
Country of origin	DE

PLT-SEC-T3-3S-230-FM - Type 3 surge protection device



2905230

<https://www.phoenixcontact.com/us/products/2905230>

Technical data

Product properties

Product type	Device protection
Product family	SEC Family
IEC power supply system	TN-S
	TT
Type	DIN rail module, two-section, divisible
Number of positions	4
Surge protection fault message	Optical, remote indicator contact

Insulation characteristics

Overvoltage category	III
Pollution degree	2
IEC test classification	III
	T3
EN type	T3
Number of ports	One

Electrical properties

Indicator/remote signaling

Connection name	Remote fault indicator contact
Switching function	N/C contact
Operating voltage	250 V AC
	125 V DC (200 mA DC)
Operating current	3 A AC
	1 A DC (30 V DC)

Connection data

Connection method	Screw connection
Screw thread	M3
Tightening torque	0.8 Nm
Conductor cross section flexible	0.2 mm ² ... 2.5 mm ²
Conductor cross section rigid	0.2 mm ² ... 4 mm ²
Conductor cross section AWG	24 ... 12

Dimensions

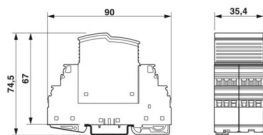
Dimensional drawing	
Width	35.4 mm

PLT-SEC-T3-3S-230-FM - Type 3 surge protection device



2905230

<https://www.phoenixcontact.com/us/products/2905230>

Height	90 mm
Depth	74.5 mm (incl. DIN rail 7.5 mm)
Horizontal pitch	2 Div.

Material specifications

Color (Male connector)	light grey (RAL 7035)
Color (Base element)	gray (RAL 7042)
Flammability rating according to UL 94	V-0
CTI value of material	600
Insulating material	PA 6.6-FR 20% GF PA 6.6-FR
Material group	I
Housing material	PA 6.6-FR 20 % GF PA 6.6-FR

Protective circuit

Mode of protection	L-N
	L-PE
	N-PE
Direction of action	3L-N & N-PE
Nominal voltage U_N	230/400 V AC (TN-S)
	230/400 V AC (TT - only in use with RCD)
Nominal frequency f_N	50 Hz (60 Hz)
Maximum continuous voltage U_C	264 V AC
Rated load current I_L	26 A (30 °C)
Residual current I_{PE}	$\leq 5 \mu A$
Standby power consumption P_C	$\leq 2.00 \text{ VA}$ (at U_{REF})
	$\leq 2.20 \text{ VA}$ (at U_C)
Reference test voltage U_{REF}	255.00 V AC
Nominal discharge current I_n (8/20) μs	3 kA
Combination wave U_{OC}	6 kV
Voltage protection level U_p (L-N)	$\leq 1.4 \text{ kV}$
Voltage protection level U_p (L-PE)	$\leq 1.5 \text{ kV}$
Voltage protection level U_p (N-PE)	$\leq 1.5 \text{ kV}$
TOV behavior at U_T (L-N)	440 V AC (5 s / withstand mode)
	440 V AC (120 min / withstand mode)
TOV behavior at U_T (L-PE)	440 V AC (5 s / withstand mode)
	440 V AC (120 min / withstand mode)
	1455 V AC (200 ms / safe failure mode)
TOV behavior at U_T (N-PE)	1200 V AC (200 ms / safe failure mode)
Response time t_A (L-N)	$\leq 25 \text{ ns}$
Response time t_A (L-PE)	$\leq 100 \text{ ns}$
Response time t_A (N-PE)	$\leq 100 \text{ ns}$
Short-circuit current rating I_{SCCR}	1.5 kA AC

PLT-SEC-T3-3S-230-FM - Type 3 surge protection device



2905230

<https://www.phoenixcontact.com/us/products/2905230>

Max. backup fuse with branch wiring	not required
-------------------------------------	--------------

Environmental and real-life conditions

Ambient conditions

Degree of protection	IP20
Ambient temperature (operation)	-40 °C ... 70 °C
Ambient temperature (storage/transport)	-40 °C ... 70 °C
Altitude	≤ 2000 m (amsl)
Permissible humidity (operation)	5 % ... 95 %
Shock (operation)	30g (Half-sine / 11 ms / 3x ±X, ±Y, ±Z)
Vibration (operation)	5g (10 ... 150 Hz/20 cycles/axis/X, Y, Z)

Standards and regulations

Standards/specifications	IEC 61643-11
Note	2011

EN 61643-11

Standards/specifications	EN 61643-11
Note	2012

Mounting

Mounting type	DIN rail: 35 mm
---------------	-----------------

PLT-SEC-T3-3S-230-FM - Type 3 surge protection device



2905230

<https://www.phoenixcontact.com/us/products/2905230>

Drawings

Product drawing

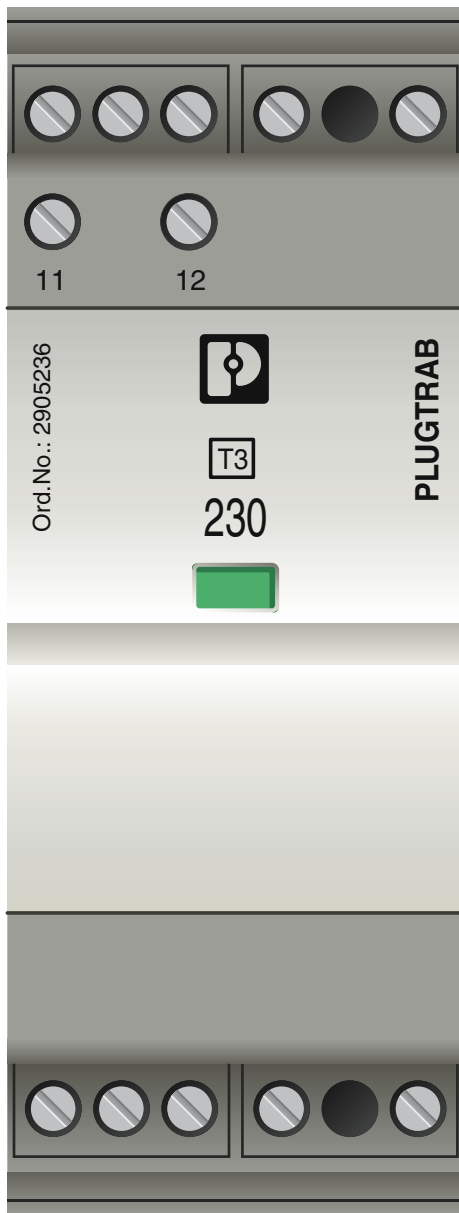

PLT-SEC-T3-3S-230-FM - Type 3 surge protection device



2905230

<https://www.phoenixcontact.com/us/products/2905230>

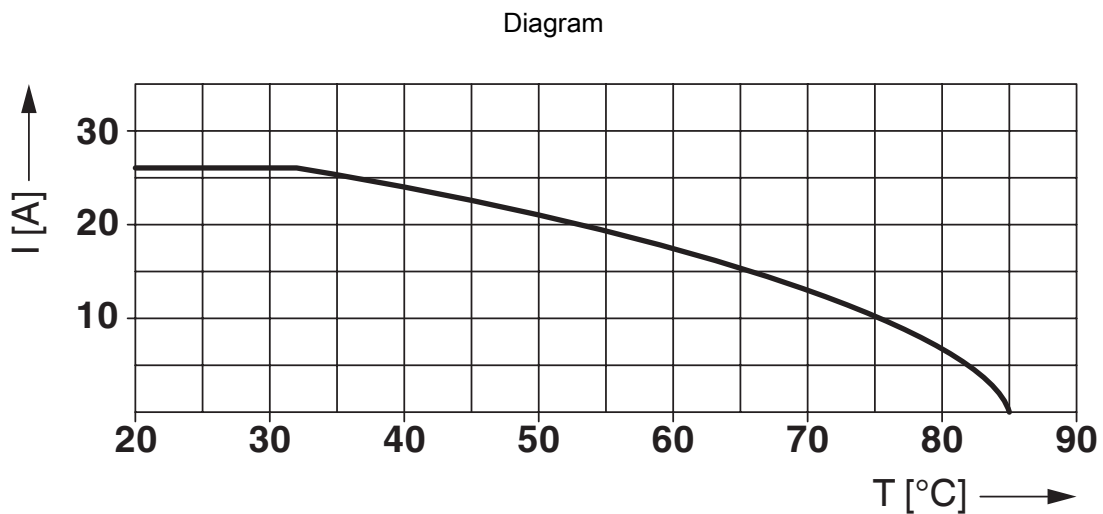
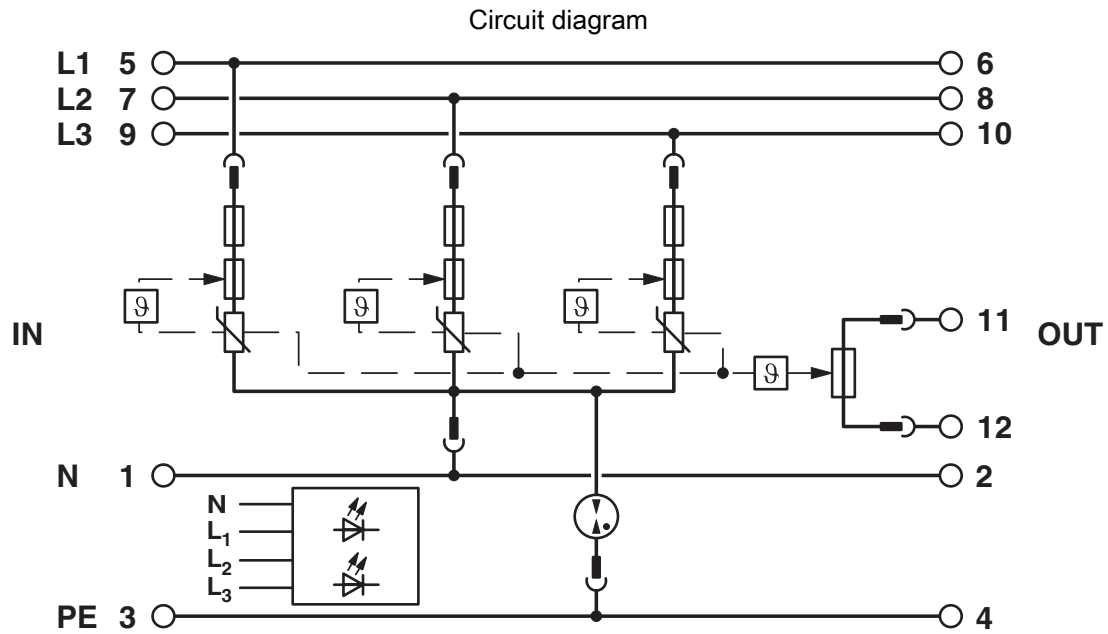

Nominal current depending on ambient temperature

PLT-SEC-T3-3S-230-FM - Type 3 surge protection device



2905230

<https://www.phoenixcontact.com/us/products/2905230>

Dimensional drawing

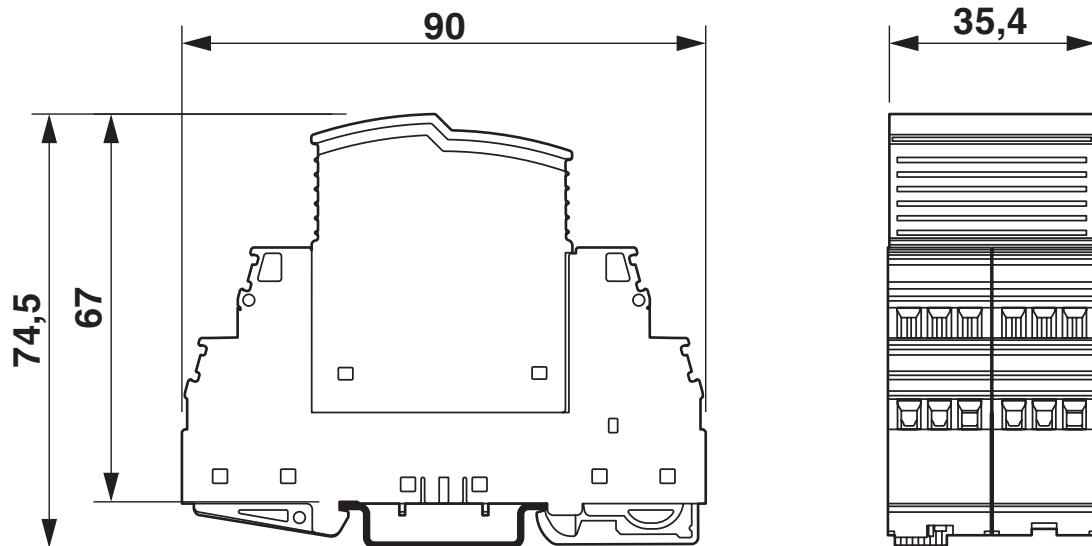

PLT-SEC-T3-3S-230-FM - Type 3 surge protection device



2905230

<https://www.phoenixcontact.com/us/products/2905230>

Approvals

🔗 To download certificates, visit the product detail page: <https://www.phoenixcontact.com/us/products/2905230>



EAC

Approval ID: RU C-DE.*09.B.00169

UAE-RoHS

Approval ID: 23-10-88891

PLT-SEC-T3-3S-230-FM - Type 3 surge protection device



2905230

<https://www.phoenixcontact.com/us/products/2905230>

Classifications

ECLASS

ECLASS-11.0	27130806
ECLASS-13.0	27171203

ETIM

ETIM 9.0	EC000942
----------	----------

UNSPSC

UNSPSC 21.0	39121600
-------------	----------

PLT-SEC-T3-3S-230-FM - Type 3 surge protection device



2905230

<https://www.phoenixcontact.com/us/products/2905230>

Environmental product compliance

EU RoHS

Fulfills EU RoHS substance requirements	Yes
Exemption	7(a), 7(c)-I

China RoHS

Environment friendly use period (EFUP)	EFUP-50
	An article-related China RoHS declaration table can be found in the download area for the respective article under "Manufacturer declaration". For all articles with EFUP-E, no China RoHS declaration table issued and required.

EU REACH SVHC

REACH candidate substance (CAS No.)	1,6,7,8,9,14,15,16,17,17,18,18-Dodecachloropentacyclo[12.2.1.16,9.02,13.05,10]octadeca-7,15-diene ("Dechlorane Plus" TM)(CAS: n/a)
	Lead(CAS: 7439-92-1)
SCIP	738f5b0c-f978-4c3b-9656-9dc746b512c0

PLT-SEC-T3-3S-230-FM - Type 3 surge protection device



2905230

<https://www.phoenixcontact.com/us/products/2905230>

Accessories

CLIPFIX 35 - End bracket

3022218

<https://www.phoenixcontact.com/us/products/3022218>



Quick mounting end clamp for NS 35/7,5 DIN rail or NS 35/15 DIN rail, with marking option, width: 9.5 mm, color: gray

EML (20XE)R - Label

0803452

<https://www.phoenixcontact.com/us/products/0803452>



Label, Roll, white, unlabeled, can be labeled with: THERMOMARK E.300 (D)/600 (D), THERMOMARK ROLL 2.0, THERMOMARK ROLL, THERMOMARK ROLL X1, THERMOMARK ROLLMASTER 300/600, THERMOMARK X1.2, mounting type: adhesive, lettering field size: continuous x 20 mm, Number of individual labels: 1

PLT-SEC-T3-3S-230-FM - Type 3 surge protection device



2905230

<https://www.phoenixcontact.com/us/products/2905230>

EML (20XE)R YE - Label

0803453

<https://www.phoenixcontact.com/us/products/0803453>



Label, Roll, yellow, unlabeled, can be labeled with: THERMOMARK E.300 (D)/600 (D), THERMOMARK ROLL 2.0, THERMOMARK ROLL, THERMOMARK ROLL X1, THERMOMARK ROLLMASTER 300/600, THERMOMARK X1.2, mounting type: adhesive, lettering field size: continuous x 20 mm, Number of individual labels: 1

X-PEN 0,35 - Marker pen

0811228

<https://www.phoenixcontact.com/us/products/0811228>



Marker pen without ink cartridge, for manual labeling of markers, labeling extremely wipe-proof, line thickness 0.35 mm

PLT-SEC-T3-3S-230-FM - Type 3 surge protection device



2905230

<https://www.phoenixcontact.com/us/products/2905230>

SZS 0,6X3,5 VDE - Screwdriver

1212602

<https://www.phoenixcontact.com/us/products/1212602>



Screwdriver, slot-headed, VDE insulated, size: 0.6 x 3.5 x 100 mm, 2-component grip, with non-slip grip

PLT-SEC-T3-3S-230-P - Type 3 surge protection plug

2905236

<https://www.phoenixcontact.com/us/products/2905236>



Replacement plug for type 3 device protection from the PLUGTRAB SEC T3 3S product range. 230 V nominal voltage.

Phoenix Contact 2024 © - all rights reserved
<https://www.phoenixcontact.com>

Phoenix Contact USA
586 Fulling Mill Road
Middletown, PA 17057, United States
(+717) 944-1300
info@phoenixcon.com